

ORDINANCE NO. 2017-39

AN ORDINANCE OF THE CITY OF WYLIE, TEXAS, REPEALING ORDINANCE NO. 2012-38; ADOPTING THE 2015 EDITION OF THE INTERNATIONAL RESIDENTIAL CODE, SAVE AND EXCEPT THE DELETIONS AND AMENDMENTS SET FORTH HEREIN; PROVIDING FOR A PENALTY FOR THE VIOLATION OF THIS ORDINANCE; PROVIDING FOR REPEALING, SAVINGS AND SEVERABILITY CLAUSES; PROVIDING FOR AN EFFECTIVE DATE OF THIS ORDINANCE; AND PROVIDING FOR THE PUBLICATION OF THE CAPTION HEREOF.

WHEREAS, the City Council of the City of Wylie, Texas ("City Council") has investigated and determined that it would be advantageous and beneficial to the citizens of the City of Wylie, Texas ("Wylie") to repeal Wylie Ordinance No. 2012-38; and

WHEREAS, the City Council has investigated and determined that it would be advantageous and beneficial to the citizens of Wylie to adopt the 2015 Edition of the International Residential Code for one and two family dwellings, save and except the deletions and amendments set forth below.

NOW, THEREFORE, BE IT ORDAINED BY THE CITY COUNCIL OF THE CITY OF WYLIE, TEXAS:

SECTION 1: Findings Incorporated. The findings set forth above are incorporated into the body of this Ordinance as if fully set forth herein.

SECTION 2: Ordinance No. 2012-38 Repealed. Wylie Ordinance No. 2012-38 is repealed in its entirety and replaced by this Ordinance. The effective date of the repeal discussed in this Section shall not occur until the effective date of this Ordinance at which time Ordinance No. 2012-38 shall be repealed. Such repeal shall not abate any pending prosecution and/or lawsuit or prevent any prosecution and/or lawsuit from being commenced for any violation of Ordinance No. 2012-38 occurring before the effective date of this Ordinance.

SECTION 3: Adoption of the 2015 International Residential Code. The International Residential Code, copyrighted by the International Code Council, Inc., save and except the amendments set forth in Exhibit "A", attached hereto and incorporated herein for all purposes, is hereby adopted as the One and Two Family Building Code for Wylie, prescribing regulations applicable to all residential and existing premises structures and constitutes minimum requirements and standards for residential and existing premises construction applications (the "2015 International Residential Code"). The 2015 International Residential Code is made a part of this Ordinance as if fully set forth herein. One (1) copy of the 2015 International Residential Code is on file in the office of the City Secretary of Wylie being marked and designated as the 2015 International Residential Code.

SECTION 4: Savings/Repealing Clause. All provisions of any ordinance in conflict with this Ordinance are hereby repealed to the extent they are in conflict; but such repeal shall not abate any pending prosecution for violation of the repealed ordinance, nor shall the repeal prevent a prosecution from being commenced for any violation if occurring prior to the repeal of the ordinance. Any remaining portion of conflicting ordinances shall remain in full force and effect. A reference in any ordinance to an earlier or different version of a building code is hereby amended to refer to the 2015 International Residential Code as it is adopted herein or may be subsequently amended.

SECTION 5: Penalty Provision. Any person, firm, corporation or entity violating this Ordinance shall be deemed guilty of a misdemeanor, and upon conviction thereof shall be subject to a fine not to exceed the sum of TWO THOUSAND AND NO/100 DOLLARS (\$2,000.00). Each continuing day's violation under this Ordinance shall constitute a separate offense. The penal provisions imposed under this Ordinance shall not preclude Wylie from filing suit to enjoin the violation. Wylie retains all legal rights and remedies available to it pursuant to local, state and federal law.

SECTION 6: Severability. If any section, subsection, sentence, clause or phrase of this Ordinance is for any reason, held to be unconstitutional or invalid by a court of competent jurisdiction, such decision shall not affect the validity of the remaining portions of this Ordinance. Wylie hereby declares that it would have passed this Ordinance, and each section, subsection, clause or phrase thereof, irrespective of the fact that any one or more sections, subsections, sentences, clauses, and phrases be declared unconstitutional.

SECTION 7: Effective Date. This Ordinance shall become effective upon its passage and publication as required by the City Charter and by law.

DULY PASSED AND APPROVED BY THE CITY COUNCIL OF THE CITY OF WYLIE, TEXAS, on this 12th day of December, 2017.

Eric Hogue, Mayor

**ATTESTED AND CORRECTLY
RECORDED:**

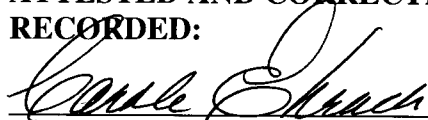
Carole Ehrlich, City Secretary

Date(s) of Publication: December 20, 2017, in the Wylie News.



Exhibit A

Recommended Amendments to the 2015 International Residential Code North Central Texas Council of Governments Region

The following sections, paragraphs, and sentences of the *2015 International Residential Code* are hereby amended as follows: Standard type is text from the IRC.

In 2009, the State Legislature enacted SB 1410 prohibiting cities from enacting fire sprinkler mandates in residential dwellings. However, jurisdictions with ordinances that required sprinklers for residential dwellings prior to and enforced before January 1, 2009, may remain in place. Reference; Section R313 Automatic Fire Sprinkler Systems.

The energy provisions in Chapter 11 of the International Residential Code (IRC) mirror the requirements of the International Energy Conservation Code (IECC). IRC Chapter 11 is deleted in its entirety. **Reference the 2015 IECC for energy code provisions and recommended amendments.**

****Section R102.4; change to read as follows:**

R102.4 Referenced codes and standards. The codes, when specifically adopted, and standards referenced in this code shall be considered part of the requirements of this code to the prescribed extent of each such reference and as further regulated in Sections R102.4.1 and R102.4.2. Whenever amendments have been adopted to the referenced codes and standards, each reference to said code and standard shall be considered to reference the amendments as well. Any reference made to NFPA 70 or the *Electrical Code* shall mean the *Electrical Code* as adopted.

(Reason: Legal wording to recognize locally adopted codes and amendments adopted with referenced codes. Note: the former ICC Electrical Code is now Appendix K of the IBC, but no longer called by that name. If adopting in that location, be sure to include language that includes structures under IRC and IBC.)

****Section R104.10.1 Flood Hazard areas; delete this section.**

(Reason: Flood hazard ordinances may be administered by other departments within the city.)

****Section R105.3.1.1 & R106.1.4; delete these sections.**

(Reason: Floodplain provisions are addressed locally.)

****Section R110 (R110.1 through R110.5); delete the section.**

(Reason: Issuing CO's for residences is not a common practice in the area.)

****Section R202; change definition of "Townhouse" to read as follows:**

TOWNHOUSE. A single-family dwelling unit constructed in a group of three or more attached units separated by property lines in which each unit extends from foundation to roof and with a yard or public way on at least two sides.

(Reason: To distinguish Townhouses on separate lots.)

****Table R301.2 (1); fill in as follows:**

GROUND SNOW LOAD	WIND DESIGN				SEISMIC DESIGN CATEGORY ^f	SUBJECT TO DAMAGE FROM			WINTER DESIGN TEMP ^e	ICE BARRIER UNDER-LAYMENT ^h	FLOOD HAZARDS ^g	AIR FREEZING INDEX ⁱ	MEAN ANNUAL TEMP ^j
	SPEED ^d (MPH)	Topographic Effects ^k	Special Wind Region ^l	Windborne Debris Zone ^m		Weathering ^a	Frost Line Depth ^b	Termite ^c					
5 lb/ft	115 (3 sec-gust)/ 76 fastest mile	No	No	No	A	Moderate	6"	Very Heavy	22 ^o F	No	Local Code	150	64.9 ^o F

(Reason: To promote regional uniformity.)

****Section R302.1; add exception #6 to read as follows:**

Exceptions: {previous exceptions unchanged}

6. Open non-combustible carport structures may be constructed when also approved within adopted ordinances.

(Reason: Refers to other ordinances, such as zoning ordinances.)

****Section R302.3; add Exception #3 to read as follows:**

Exceptions:

1. {existing text unchanged}
2. {existing text unchanged}
3. Two-family dwelling units that are also divided by a property line through the structure shall be separated as required for townhouses.

(Reason: Provide guidance for a common construction method in this area. Correlates with amendment to IRC Section R202 Townhouse definition.)

*****Section R302.5.1; change to read as follows:**

R302.5.1 Opening protection. Openings from a private garage directly into a room used for sleeping purposes shall not be permitted. Other openings between the garage and residence shall be equipped with solid wood doors not less than 13/8 inches (35 mm) in thickness, solid or honeycomb core steel doors not less than 13/8 inches (35 mm) thick, or 20-minute fire-rated doors.

(Reason: Absence of data linking self-closing devices to increased safety. Self-closing devices often fail to close the door entirely.)

****Section R303.3, Exception; amend to read as follows:**

Exception: {existing text unchanged} Exhaust air from the space shall be exhaust out to the outdoors unless the space contains only a water closet, a lavatory, or water closet and a lavatory may

be ventilated with an approved mechanical recirculating fan or similar device designed to remove odors from the air.

(Reason: Consistent with common local practice as recirculating fans are recognized as acceptable air movement.)

Section R313 Automatic Fire Sprinkler Systems. Delete subsections in their entirety.

(Reason: In 2009, the State Legislature enacted SB 1410 prohibiting cities from enacting fire sprinkler mandates in residential dwellings. However, jurisdictions with ordinances that required sprinklers for residential dwellings prior to and enforced before January 1, 2009, may remain in place.)

*****Section R315.2.2 Alterations, repairs and additions. Amend to read as follows:**

Exception:

2. Installation, alteration or repairs of electrical powered.. *{remaining text unchanged}*

(Reason: Code intent is to protect against the products of combustion.)

****Section R322 Flood Resistant Construction. Deleted Section.**

(Reason: Floodplain hazard ordinances may be administered by other departments within the city.)

*****Section R326 Swimming Pools, Spas and Hot Tubs. Amended to read as follows:**

R326.1 General. The design and construction of pools and spas shall comply with the **2015 IRC Appendix Q. Swimming Pools, Spas and Hot Tubs.**

(Reason: New Pool and Spa code not under review. In lieu of adoption of new pool code, previous edition of 2012 Appendix G is proposed for continued use but renamed 2015 Appendix Q.)

****Section R401.2, amended by adding a new paragraph following the existing paragraph to read as follows.**

Section R401.2. Requirements. *{existing text unchanged}* ...

Every foundation and/or footing, or any size addition to an existing post-tension foundation, regulated by this code shall be designed and sealed by a Texas-registered engineer.

(Amendment to 2012 IRC carried forward to 2015 IRC.)

****Section R602.6.1; amend the following:**

R602.6.1 Drilling and notching of top plate. When piping or ductwork is placed in or partly in an exterior wall or interior load-bearing wall, necessitating cutting, drilling or notching of the top plate by more than 50 percent of its width, a galvanized metal tie not less than 0.054 inch thick (1.37 mm) (16 Ga) and 5 inches (127 mm) wide shall be fastened across and to the plate at each side of the opening with not less than eight 10d (0.148 inch diameter) having a minimum length of 1 ½ inches (38 mm) at each side or equivalent. Fasteners will be offset to prevent splitting of the top plate material. The metal tie must extend a minimum of 6 inches past the opening. See figure R602.6.1. *{remainder unchanged}*

(Amendment to 2012 IRC carried forward to 2015 IRC.)

****Figure R602.6.1; delete the figure and insert the following figure:**

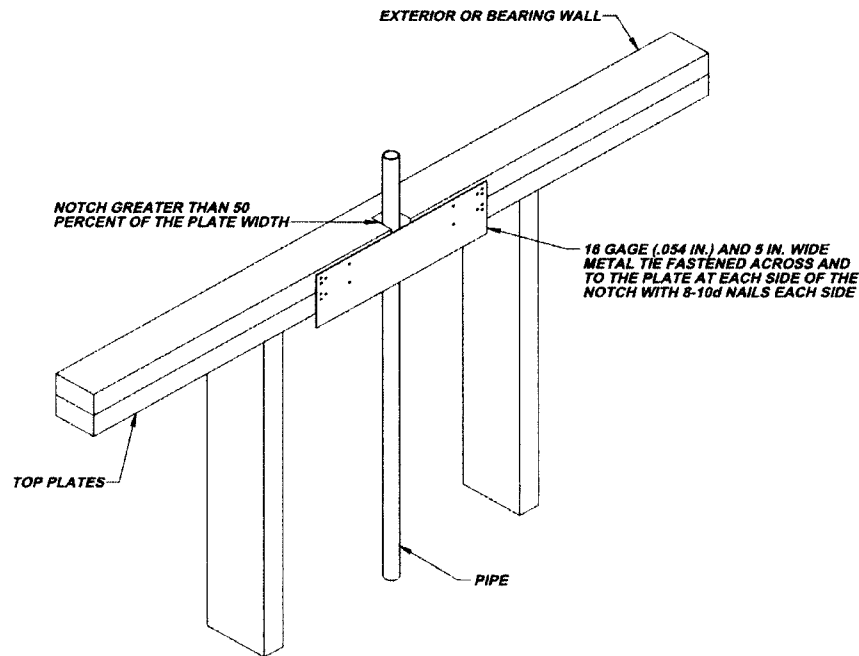

(Amendment to 2012 IRC carried forward to 2015 IRC also provides additional assurance of maintaining the integrity of the framing by spreading the nailing pattern.)

****Section R703.8.4.1; add a second paragraph to read as follows:**

In stud framed exterior walls, all ties shall be anchored to studs as follows:

1. When studs are 16 in (407 mm) o.c., stud ties shall be spaced no further apart than 24 in (737 mm) vertically starting approximately 12 in (381 mm) from the foundation; or
2. When studs are 24 in (610 mm) o.c., stud ties shall be spaced no further apart than 16 in (483 mm) vertically starting approximately 8 in (254 mm) from the foundation.

(Reason: (Amendment to 2012 IRC carried forward to 2015 IRC. Provide easy to install and inspect dimensions to clarify how to anchor and to distinguish "studs" from other types of construction.)

****Section R902.1; Amend and add exception #3 to read as follows:**

R902.1 Roofing covering materials. Roofs shall be covered with materials as set forth in Sections R904 and R905. Class A, B, or C roofing shall be installed. *{remainder unchanged}*

Exceptions:

1. *{text unchanged}*
2. *{text unchanged}*
3. *{text unchanged}*
4. *{text unchanged}*

Ordinance No. 2017-39

Repealing Ordinance No. 2012-38; Adopting the 2015 Edition of the International Residential Code

5. Non-classified roof coverings shall be permitted on one-story detached *accessory structures* used as tool and storage sheds, playhouses and similar uses, provided the floor area does not exceed (area defined by jurisdiction).

(Reason: to address accessory structures Group U exempt from permits per Section R105.2)

***** Chapter 11 [RE] – Energy Efficiency is deleted in its entirety and replaced with the following:**

N1101.1 Scope. This chapter regulates the energy efficiency for the design and construction of buildings regulated by this code.

N1101.2 Compliance. Compliance shall be demonstrated by meeting the requirements of the residential provisions of 2015 International Energy Conservation Code.

(Reason: The text of the residential provisions of the 2015 IRC is extracted from the 2015 edition of the International Energy Conservation Code—Residential Provisions and has been editorially revised to conform to the scope and application of this code. The section numbers appearing in parenthesis after each section number are the section numbers of the corresponding text in the International Energy Conservation Code—Residential Provisions. This approach simply minimizes the number of amendments to the IRC)

****Section M1305.1.3; change to read as follows:**

M1305.1.3 Appliances in attics. Attics containing *appliances* shall be provided . . . *{bulk of paragraph unchanged}* . . . sides of the *appliance* where access is required. The clear access opening dimensions shall be a minimum of 20 inches by 30 inches (508 mm by 762 mm), or larger and large enough to allow removal of the largest *appliance*. A walkway to an *appliance* shall be rated as a floor as approved by the building official. As a minimum, for *access* to the attic space, provide one of the following:

1. A permanent stair.
2. A pull down stair with a minimum 300 lb (136 kg) capacity.
3. An *access* door from an upper floor level.

Exceptions:

1. The passageway and level service space are not required where the *appliance* can be serviced and removed through the required opening.
2. Where the passageway is unobstructed...*{remaining text unchanged}*

(Reason: To provide a safe means of accessibility to appliances in attics and to allow for different types of construction limitations. Consistent with regional amendment to IFGC and IMC 306.3.)

****Section M1411.3; change to read as follows:**

M1411.3 Condensate disposal. Condensate from all cooling coils or evaporators shall be conveyed from the drain pan outlet to a sanitary sewer through a trap, by means of a direct or indirect drain. . Each cooling coil condensate drain shall run separately to the point of disposal and may not be interconnected to other condensate drains. *{remaining text unchanged}*

(Reason: Reflects regional practice and to reduce excessive runoff into storm drains.)

****Section M1411.3.1, Items 3 and 4; add text to read as follows:**

Ordinance No. 2017-39

Repealing Ordinance No. 2012-38; Adopting the 2015 Edition of the International Residential Code

M1411.3.1 Auxiliary and secondary drain systems. *{bulk of paragraph unchanged}*

1. *{text unchanged}*
2. *{text unchanged}*
3. An auxiliary drain pan... *{bulk of text unchanged}*... with Item 1 of this section. A water level detection device may be installed only with prior approval of the *building official*.
4. A water level detection device... *{bulk of text unchanged}*... overflow rim of such pan. A water level detection device may be installed only with prior approval of the *building official*.

(Reason: Reflects standard practice in this area.)

****Section M1411.3.1.1; add text to read as follows:**

M1411.3.1.1 Water-level monitoring devices. On down-flow units ...*{bulk of text unchanged}*... installed in the drain line. A water level detection device may be installed only with prior approval of the *building official*.

(Reason: Reflects standard practice in this area.)

****M1503.4 Makeup Air Required Amend and add exception as follows:**

M1503.4 Makeup air required. Exhaust hood systems capable of exhausting in excess of 400 cubic feet per minute (0.19 m³/s) shall be provided with makeup air at a rate approximately equal to the difference between the exhaust air rate and 400 cubic feet per minute. Such makeup air systems shall be equipped with a means of closure and shall be automatically controlled to start and operate simultaneously with the exhaust system.

Exception: Where all appliances in the house are of sealed combustion, power-vent, unvented, or electric, the exhaust hood system shall be permitted to exhaust up to 600 cubic feet per minute (0.28 m³/s) without providing makeup air. Exhaust hood systems capable of exhausting in excess of 600 cubic feet per minute (0.28 m³/s) shall be provided with a makeup air at a rate approximately equal to the difference between the exhaust air rate and 600 cubic feet per minute.

(Reason: Exception requires makeup air equaling the amount above and beyond 400 cfm for larger fan which will address concerns related to "fresh" air from the outdoors in hot humid climates creating a burden on HVAC equipment and negative efficiency impacts from back-drafting and wasted energy.

****Section M2005.2; change to read as follows:**

M2005.2 Prohibited locations. Fuel-fired water heaters shall not be installed in a room used as a storage closet. Water heaters located in a bedroom or bathroom shall be installed in a sealed enclosure so that *combustion air* will not be taken from the living space. Access to such enclosure may be from the bedroom or bathroom when through a solid door, weather-stripped in accordance with the exterior door air leakage requirements of the *International Energy Conservation Code* and equipped with an *approved* self-closing device. Installation of direct-vent water heaters within an enclosure is not required

(Reason: Corresponds with the provisions of IFGC Section 303, exception #5.)

****Section G2415.2.1 (404.2.1); add a second paragraph to read as follows:**

Both ends of each section of medium pressure gas piping shall identify its operating gas pressure with an *approved* tag. The tags are to be composed of aluminum or stainless steel and the following wording shall be stamped into the tag:

"WARNING: 1/2 to 5 psi gas pressure - Do Not Remove"

(Reason: To protect homeowners and plumbers.)

****Section G2415.2.2 (404.2.2); add an exception to read as follows:**

Exception: Corrugated stainless steel tubing (CSST) shall be a minimum of 1/2" (18 EDH).

(Reason: Pipe less than 1/2" has a history in this region of causing whistling.)

****Section G2415.12 (404.12); change to read as follows:**

G2415.12 (404.12) Minimum burial depth. Underground *pipng* systems shall be installed a minimum depth of 18 inches (457 mm) below grade.

(Reason: To provide increased protection to piping systems.)

****Section G2417.1 (406.1); change to read as follows:**

G2417.1 (406.1) General. Prior to acceptance and initial operation, all *pipng* installations shall be inspected and *pressure tested* to determine that the materials, design, fabrication, and installation practices comply with the requirements of this *code*. The *permit* holder shall make the applicable tests prescribed in Sections 2417.1.1 through 2417.1.5 to determine compliance with the provisions of this *code*. The *permit* holder shall give reasonable advance notice to the *building official* when the *pipng* system is ready for testing. The *equipment*, material, power and labor necessary for the inspections and test shall be furnished by the *permit* holder and the *permit* holder shall be responsible for determining that the work will withstand the test pressure prescribed in the following tests.

(Reason: To utilize language used in the IPC regarding who is responsible for testing procedures.)

****Section G2417.4; change to read as follows:**

G2417.4 (406.4) Test pressure measurement. Test pressure shall be measured with a monometer or with a pressure-measuring device designed and calibrated to read, record, or indicate a pressure loss caused by leakage during the pressure test period. The source of pressure shall be isolated before the pressure tests are made.

(Reason: To require the use of more accurate diaphragm gauges. Spring gauges do not provide accurate measurement below approximately 17 psig.)

****Section G2417.4.1; change to read as follows:**

G2417.4.1 (406.4.1) Test pressure. The test pressure to be used shall be no less than 3 psig (20 kPa gauge), or at the discretion of the Code Official, the piping and valves may be tested at a pressure of at least six (6) inches (152 mm) of mercury, measured with a manometer or slope gauge. For tests requiring a pressure of 3 psig, diaphragm gauges shall utilize a dial with a minimum diameter of three and one half inches (3 1/2"), a set hand, 1/10 pound incrementation and pressure range not to exceed 6 psi for tests requiring a pressure of 3 psig. For tests requiring a pressure of 10 psig, diaphragm gauges shall utilize a dial with a minimum diameter of three and one-half inches (3 1/2"), a set hand, a minimum of 2/10 pound incrementation and a pressure range not to exceed 20 psi. For welded piping, and for piping carrying gas at pressures in excess of fourteen (14) inches water column pressure (3.48 kPa) (1/2 psi) and less than 200 inches of water column pressure (52.2 kPa) (7.5 psi), the test pressure shall not be less than ten (10) pounds per square inch (69.6 kPa). For piping carrying gas at a pressure

Ordinance No. 2017-39

Repealing Ordinance No. 2012-38; Adopting the 2015 Edition of the International Residential Code

that exceeds 200 inches of water column (52.2 kPa) (7.5 psi), the test pressure shall be not less than one and one-half times the proposed maximum working pressure.

Diaphragm gauges used for testing must display a current calibration and be in good working condition. The appropriate test must be applied to the diaphragm gauge used for testing

(Reason: To provide for lesser pressures to coordinate with the use of more accurate diaphragm gauges.)

****Section G2417.4.2; change to read as follows:**

G2417.4.2 (406.4.2) Test duration. The test duration shall be held for a length of time satisfactory to the *Building Official*, but in no case for be not less than fifteen (15) minutes. For welded *pipng*, and for *pipng* carrying gas at pressures in excess of fourteen (14) inches water column pressure (3.48 kPa), the test duration shall be held for a length of time satisfactory to the *Building Official*, but in no case for less than thirty (30) minutes.

(Reason: To comply with accepted regional practices.)

****Section G2420.1 (406.1); add Section G2420.1.4 to read as follows:**

G2420.1.4 Valves in CSST installations. Shutoff *valves* installed with corrugated stainless steel (CSST) *pipng systems* shall be supported with an approved termination fitting, or equivalent support, suitable for the size of the *valves*, of adequate strength and quality, and located at intervals so as to prevent or damp out excessive vibration but in no case greater than 12-inches from the center of the *valve*. Supports shall be installed so as not to interfere with the free expansion and contraction of the system's *pipng*, fittings, and *valves* between anchors. All *valves* and supports shall be designed and installed so they will not be disengaged by movement of the supporting *pipng*.

(Reason: To provide proper security to CSST valves. These standards were established in this region in 1999 when CSST was an emerging technology.)

****Section G2420.5.1 (409.5.1); add text to read as follows:**

G2420.5.1 (409.5.1) Located within the same room. The shutoff valve ...*{bulk of paragraph unchanged}*... in accordance with the appliance manufacturer's instructions. A secondary shutoff valve must be installed within 3 feet (914 mm) of the firebox if appliance shutoff is located in the firebox.

(Reason: Reflects regional practice and provides an additional measure of safety.)

****Section G2421.1 (410.1); add text and Exception to read as follows:**

G2421.1 (410.1) Pressure regulators. A line *pressure regulator* shall be ... *{bulk of paragraph unchanged}*... approved for outdoor installation. Access to *regulators* shall comply with the requirements for access to *appliances* as specified in Section M1305.

Exception: A passageway or level service space is not required when the *regulator* is capable of being serviced and removed through the required *attic* opening.

(Reason: To require adequate access to regulators.)

****Section G2445.2 (621.2); add Exception to read as follows:**

G2445.2 (621.2) Prohibited use. One or more *unvented room heaters* shall not be used as the sole source of comfort heating in a *dwelling unit*.

Exception: Existing *approved unvented room heaters* may continue to be used in *dwelling units*, in accordance with the *code* provisions in effect when installed, when *approved* by the *Building Official* unless an unsafe condition is determined to exist as described in *International Fuel Gas Code* Section 108.7 of the Fuel Gas Code.

(Reason: Gives code official discretion.)

****Section G2448.1.1 (624.1.1); change to read as follows:**

G2448.1.1 (624.1.1) Installation requirements. The requirements for *water heaters* relative to access, sizing, *relief valves*, drain pans and scald protection shall be in accordance with this *code*.

(Reason: To clarify installation requirements. Also corresponds with amendments regarding water heater access.)

***** Section P2801.6.1; change to read as follows:**

Section P2801.6.1 Pan size and drain. The pan shall be not less than 1 1/2 inches (38 mm) in depth and shall be of sufficient size and shape to receive all dripping or condensate from the tank or water heater. The pan shall be drained by an indirect waste pipe having a diameter of not less than 3/4 inch (19 mm). Piping for safety pan drains shall be of those materials listed in Table 605.4. Multiple pan drains may terminate to a single discharge piping system when *approved* by the administrative authority and permitted by the manufactures installation instructions and installed with those instructions.

***** Section P2804.6.1; change to read as follows:**

Section P2804.6.1 Requirements for discharge piping. The discharge piping serving a pressure relief valve, temperature relief valve or combination thereof shall:

1. Not be directly connected to the drainage system.
2. Discharge through an air gap.
3. Not be smaller than the diameter of the outlet of the valve served and shall discharge full size to the air gap.
4. Serve a single relief device and shall not connect to piping serving any other relief device or equipment.

Exception: Multiple relief devices may be installed to a single T & P discharge piping system when approved by the administrative authority and permitted by the manufactures installation instructions and installed with those instructions.

5. Discharge to an indirect waste receptor or to the outdoors.

[remainder unchanged]

(Reason: To ensure the T&P is ran to the exterior.)

****Section P2801.7; add Exception to read as follows:**

Exceptions:

1. Electric Water Heater.

(Reason: To coordinate with Section 2408.2 of the IRC, which recognizes this exception.)

Ordinance No. 2017-39

Repealing Ordinance No. 2012-38; Adopting the 2015 Edition of the International Residential Code

****Section P2902.5.3; change to read as follows:**

P2902.5.3 Lawn irrigation systems. The potable water supply to lawn irrigation systems shall be protected against backflow by an atmospheric-type vacuum breaker, a pressure-type vacuum breaker, a double-check assembly or a reduced pressure principle backflow preventer. A valve shall not be installed downstream from an atmospheric vacuum breaker. Where chemicals are introduced into the system, the potable water supply shall be protected against backflow by a reduced pressure principle backflow preventer.

(Reason: To provide clarity.)

*****Section P3009.9; change to read as follows:**

P3003.9. Solvent cementing. Joint surfaces shall be clean and free from moisture. A purple primer that conforms to ASTM F 656 shall be applied. Solvent cement not purple in color and conforming to ASTM D 2564, CSA B137.3, CSA B181.2 or CSA B182.1 shall be applied to all joint surfaces. The joint shall be made while the cement is wet and shall be in accordance with ASTM D 2855. Solvent cement joints shall be permitted above or below ground.

(Reasoning: to keep the "process of joining PVC pipe)

****Section P3112.2; delete and replace with the following:**

P3112.2 Installation. Traps for island sinks and similar equipment shall be roughed in above the floor and may be vented by extending the vent as high as possible, but not less than the drainboard height and then returning it downward and connecting it to the horizontal sink drain immediately downstream from the vertical fixture drain. The return vent shall be connected to the horizontal drain through a wye-branch fitting and shall, in addition, be provided with a foot vent taken off the vertical fixture vent by means of a wye-branch immediately below the floor and extending to the nearest partition and then through the roof to the open air or may be connected to other vents at a point not less than six (6) inches (152 mm) above the flood level rim of the fixtures served. Drainage fittings shall be used on all parts of the vent below the floor level and a minimum slope of one-quarter (1/4) inch per foot (20.9 mm/m) back to the drain shall be maintained. The return bend used under the drain-board shall be a one (1) piece fitting or an assembly of a forty-five (45) degree (0.79 radius), a ninety (90) degree (1.6 radius) and a forty-five (45) degree (0.79 radius) elbow in the order named. Pipe sizing shall be as elsewhere required in this Code. The island sink drain, upstream of the return vent, shall serve no other fixtures. An accessible cleanout shall be installed in the vertical portion of the foot vent.

(Reason: To clarify the installation of island venting and to provide a regional guideline on a standard installation method for this region.)

*****Appendix Q Reserved. Amended to read as follows:**

Appendix Q. Swimming Pools, Spas and Hot Tubs.

SECTION AQ101 GENERAL

AQ101.1 General.

The provisions of this appendix shall control the design and construction of swimming pools, spas and hot tubs installed in or on the lot of a one- or two-family dwelling.

Ordinance No. 2017-39

Repealing Ordinance No. 2012-38; Adopting the 2015 Edition of the International Residential Code

AQ101.2 Pools in flood hazard areas.

Pools that are located in flood hazard areas established by Table R301.2(1), including above-ground pools, on-ground pools and in-ground pools that involve placement of fill, shall comply with Section AQ101.2.1 or AQ101.2.2.

Exception: Pools located in riverine flood hazard areas which are outside of designated floodways.

AQ101.2.1 Pools located in designated floodways.

Where pools are located in designated floodways, documentation shall be submitted to the building official which demonstrates that the construction of the pool will not increase the design flood elevation at any point within the jurisdiction.

AQ101.2.2 Pools located where floodways have not been designated.

Where pools are located where design flood elevations are specified but floodways have not been designated, the applicant shall provide a floodway analysis that demonstrates that the proposed pool will not increase the design flood elevation more than 1 foot (305 mm) at any point within the jurisdiction.

SECTION AQ102 DEFINITIONS

AQ102.1 General.

For the purposes of these requirements, the terms used shall be defined as follows and as set forth in Chapter 2.

ABOVE-GROUND/ON-GROUND POOL. See "Swimming pool."

BARRIER. A fence, wall, building wall or combination thereof which completely surrounds the swimming pool and obstructs access to the swimming pool.

HOT TUB. See "Swimming pool."

IN-GROUND POOL. See "Swimming pool."

RESIDENTIAL. That which is situated on the premises of a detached one- or two-family dwelling, or a one-family townhouse not more than three stories in height.

SPA, NONPORTABLE. See "Swimming pool."

SPA, PORTABLE. A nonpermanent structure intended for recreational bathing, in which all controls, water-heating and water-circulating equipment are an integral part of the product.

SWIMMING POOL. Any structure intended for swimming or recreational bathing that contains water more than 24 inches (610 mm) deep. This includes in-ground, above-ground and on-ground swimming pools, hot tubs and spas.

SWIMMING POOL, INDOOR. A swimming pool which is totally contained within a structure and surrounded on all four sides by the walls of the enclosing structure.

SWIMMING POOL, OUTDOOR. Any swimming pool which is not an indoor pool.

SECTION AG103 SWIMMING POOLS

AQ103.1 In-ground pools.

In-ground pools shall be designed and constructed in compliance with ANSI/NSPI-5.

AQ103.2 Above-ground and on-ground pools.

Above-ground and on-ground pools shall be designed and constructed in compliance with ANSI/NSPI-4.

AQ103.3 Pools in flood hazard areas.

In flood hazard areas established by Table R301.2(1), pools in coastal high-hazard areas shall be designed and constructed in compliance with ASCE 24.

SECTION AQ104 SPAS AND HOT TUBS**AQ104.1 Permanently installed spas and hot tubs.**

Permanently installed spas and hot tubs shall be designed and constructed in compliance with ANSI/NSPI-3.

AQ104.2 Portable spas and hot tubs.

Portable spas and hot tubs shall be designed and constructed in compliance with ANSI/NSPI-6.

SECTION AQ105 BARRIER REQUIREMENTS**AQ105.1 Application.**

The provisions of this appendix shall control the design of barriers for residential swimming pools, spas and hot tubs. These design controls are intended to provide protection against potential drownings and near-drownings by restricting access to swimming pools, spas and hot tubs.

AQ105.2 Outdoor swimming pool. An outdoor swimming pool, including an in-ground, above-ground or on-ground pool, hot tub or spa shall be surrounded by a barrier which shall comply with the following:

1. The top of the barrier shall be at least 48 inches (1219mm) above grade measured on the side of the barrier, which faces away from the swimming pool. The maximum vertical clearance between grade and the bottom of the barrier shall be 2 inches (51mm) measured on the side of the barrier, which faces away from the swimming pool. Where the top of the pool structure is above grade, such as an above-ground pool, the barrier may be at ground level, such as the pool structure, or mounted on top of the pool structure. Where the barrier is mounted on top of the pool structure, the maximum vertical clearance between the top of the pool structure and the bottom of the barrier shall be 4 inches (102mm).
2. Openings in the barrier shall not allow passage of a 4-inch-diameter (102mm) sphere.
3. Solid barriers which do not have openings, such as a masonry or stone wall, shall not contain indentations or protrusions except for normal construction tolerances and tooled masonry joints.
4. Where the barrier is composed of horizontal and vertical members and the distance between the tops of the horizontal members is less than 45 inches (1143mm), the horizontal members shall be located on the swimming pool side of the fence. Spacing between vertical members shall not exceed 1.75 inches (44mm) in width. Where there are decorative cutouts within vertical members, spacing within the cutouts shall not exceed 1.75 inches (44 mm) in width.
5. Where the barrier is composed of horizontal and vertical members and the distance between the tops of the horizontal members is 45 inches (1143 mm) or more, spacing between vertical members shall not exceed 4 inches (102 mm). Where there are decorative cutouts within vertical members, spacing within the cutouts shall not exceed 1.75 inches (44 mm) in width.
6. Maximum mesh size for chain link fences shall be a 2.25-inch (57 mm) square unless the fence is provided with slats fastened at the top or the bottom which reduce the openings to not more than 1.75 inches (44 mm).
7. Where the barrier is composed of diagonal members, such as a lattice fence, the maximum opening formed by the diagonal members shall not be more than 1.75 inches (44 mm).
8. Access gates shall comply with the requirements of Section AQ105.2, Items 1 through 7, and shall be equipped to accommodate a locking device. Pedestrian access gates shall open outward away from the

Ordinance No. 2017-39

Repealing Ordinance No. 2012-38; Adopting the 2015 Edition of the International Residential Code

pool and shall be self-closing and have a self-latching device. Gates other than pedestrian access gates shall have a self-latching device. Where the release mechanism of the self-latching device is located less than 54 inches (1372 mm) from the bottom of the gate, the release mechanism and openings shall comply with the following:

8.1. The release mechanism shall be located on the pool side of the gate at least 3 inches (76 mm) below the top of the gate, and

8.2. The gate and barrier shall have not opening greater than 0.5 inch (13 mm) within 18 inches (457 mm) of the release mechanism.

9. Where a wall of a dwelling serves a part of the barrier one of the following conditions shall be met:

9.1. The pool shall be equipped with a powered safety cover in compliance with ASTM F1346; or

9.2. Doors with direct access to the pool through that wall shall be equipped with an alarm which produces an audible warning when the door and/or its screen, if present, are opened. The alarm shall be listed and labeled in accordance with UL 2017. The deactivation switch (es) shall be located at least 54 inches (1372 mm) above the threshold of the door; or

9.3. Other means of protection, such as self-closing doors with self-latching devices, which are approved by the governing body, shall be acceptable as long as the degree of protection afforded is not less than the protection afforded by Item 9.1 or 9.2 described above.

10. Where an above-ground pool structure is used as a barrier or where the barrier is mounted on top of the pool structure, and the means of access is a ladder or steps, then:

10.1. The ladder or steps shall be capable of being secured, locked or removed to prevent access, or

10.2. The ladder or steps shall be surrounded by a barrier which meets the requirements of Section AQ105.2, Items 1 through 9. When the ladder or steps are secured, locked or removed, any opening created shall not allow the passage of a 4-inch diameter (102 mm) sphere.

AQ105.3 Indoor swimming pool. Walls surrounding an indoor swimming pool shall comply with Section AQ105.2, Item 9.

AQ105.4 Prohibited locations. Barriers shall be located so as to prohibit permanent structures, equipment or similar objects from being used to climb them.

AQ105.5 Barrier exceptions. Spas or hot tubs with a safety cover which complies with ASTM F 1346, as listed in Section AQ107, shall be exempt from the provisions of this appendix

SECTION AQ106 ENTRAPMENT PROTECTION FOR SWIMMING POOL AND SPA SUCTION OUTLETS

AQ106.1 General.

Suction outlets shall be designed and installed in accordance with ANSI/APSP-7.

SECTION AQ107 ABBREVIATIONS

AQ107.1 General.

ANSI—American National Standards Institute
11 West 42nd Street
New York, NY 10036

APSP—Association of Pool and Spa Professionals
NSPI—National Spa and Pool Institute
2111 Eisenhower Avenue
Alexandria, VA 22314

ASCE—American Society of Civil Engineers
1801 Alexander Bell Drive
Reston, VA 98411-0700

Ordinance No. 2017-39

Repealing Ordinance No. 2012-38; Adopting the 2015 Edition of the International Residential Code

ASTM—ASTM International
100 Barr Harbor Drive
West Conshohocken, PA 19428

UL—Underwriters Laboratories, Inc.
333 Pfingsten Road
Northbrook, IL 60062-2096

SECTION AQ108 REFERENCED STANDARDS

AQ108.1 General.

ANSI/NSP

ANSI/NSPI- 3—99	Standard for Permanently Installed Residential Spas	AQ104.1
ANSI/NSPI- 4—99	Standard for Above-ground/ On-ground Residential Swimming Pools	AQ103.2
ANSI/NSPI- 5—03	Standard for Residential In-ground Swimming Pools	AQ103.1
ANSI/NSPI- 6—99	Standard for Residential Portable Spas	AQ104.2

ANSI/APSP

ANSI/APSP- 7—06	Standard for Suction Entrapment Avoidance in Swimming Pools, Wading Pools, Spas, Hot Tubs and Catch Basins	AQ106.1
--------------------	---	---------

ASCE

ASCE/SEI-24— 05	Flood-resistant Design and Construction	AQ103.3
--------------------	--	---------

ASTM

ASTM F 1346—91 (2003)	Performance Specification for Safety Covers and Labeling Requirements for All Covers for Swimming Pools Spas and Hot Tubs	AQ105.2, AQ105.5
-----------------------------	---	------------------

UL

UL 2017— 2000	Standard for General-purpose Signaling Devices and Systems—with revisions through June 2004	AQ105.2
------------------	--	---------

(Reason: New Pool and Spa code not under review. In lieu of adoption of new pool code, previous edition of 2012 Appendix G is proposed for continued use but renamed 2015 Appendix Q.)

END